

HORIZON[®]
H O B B Y

E-flite[®]
ADVANCING ELECTRIC FLIGHT

Opterra™ 2m

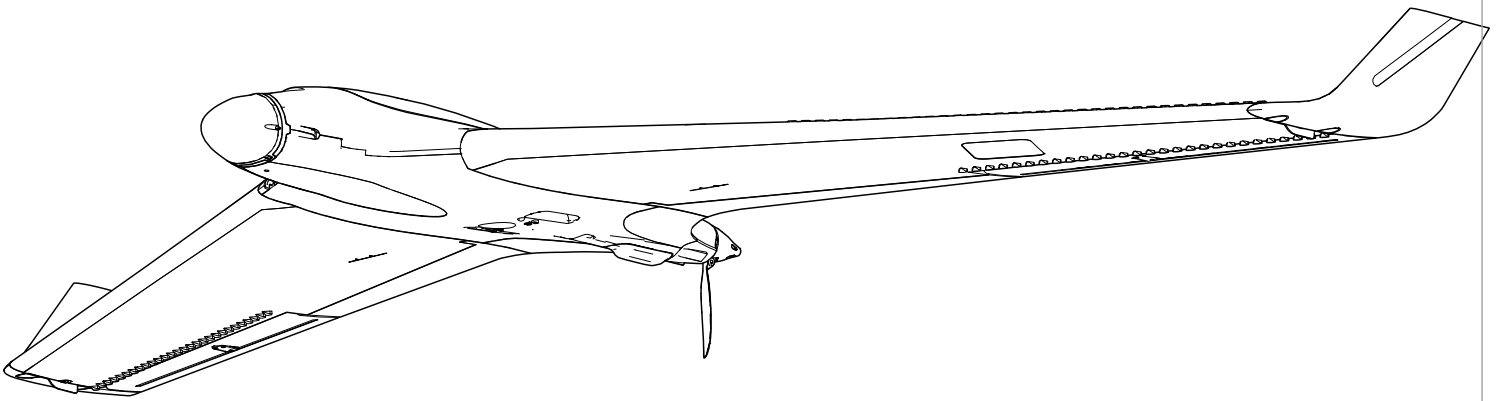

Instruction Manual
Bedienungsanleitung
Manuel d'utilisation
Manuale di Istruzioni

SAFE[®] 

SAFE[®] Select Technology, Optional Flight Envelope Protection

Bind-N-Fly[®] **Plug-N-Play**[®]
BASIC

NOTICE

All instructions, warranties and other collateral documents are subject to change at the sole discretion of Horizon Hobby, LLC. For up-to-date product literature, visit www.horizonhobby.com and click on the support tab for this product.

Meaning of Special Language:

The following terms are used throughout the product literature to indicate various levels of potential harm when operating this product:

NOTICE: Procedures, which if not properly followed, create a possibility of physical property damage AND little or no possibility of injury.

CAUTION: Procedures, which if not properly followed, create the probability of physical property damage AND a possibility of serious injury.

WARNING: Procedures, which if not properly followed, create the probability of property damage, collateral damage, and serious injury OR create a high probability of superficial injury.



WARNING: Read the ENTIRE instruction manual to become familiar with the features of the product before operating. Failure to operate the product correctly can result in damage to the product, personal property and cause serious injury.

This is a sophisticated hobby product. It must be operated with caution and common sense and requires some basic mechanical ability. Failure to operate this Product in a safe and responsible manner could result in injury or damage to the product or other property. This product is not intended for use by children without direct adult supervision. Do not use with incompatible components or alter this product in any way outside of the instructions provided by Horizon Hobby, LLC. This manual contains instructions for safety, operation and maintenance. It is essential to read and follow all the instructions and warnings in the manual, prior to assembly, setup or use, in order to operate correctly and avoid damage or serious injury.

14+

AGE RECOMMENDATION:
Not for children under 14 years. This is not a toy.



WARNING AGAINST COUNTERFEIT PRODUCTS: If you ever need to replace your Spektrum receiver found in a Horizon Hobby product, always purchase from Horizon Hobby, LLC or a Horizon Hobby authorized dealer to ensure authentic high-quality Spektrum product. Horizon Hobby, LLC disclaims all support and warranty with regards, but not limited to, compatibility and performance of counterfeit products or products claiming compatibility with DSM or Spektrum.

Safety Precautions and Warnings

As the user of this product, you are solely responsible for operating in a manner that does not endanger yourself and others or result in damage to the product or the property of others.

- Always keep a safe distance in all directions around your model to avoid collisions or injury. This model is controlled by a radio signal subject to interference from many sources outside your control. Interference can cause momentary loss of control.
- Always operate your model in open spaces away from full-size vehicles, traffic and people.
- Always carefully follow the directions and warnings for this and any optional support equipment (chargers, rechargeable battery packs, etc.).
- Always keep all chemicals, small parts and anything electrical out of the reach of children.
- Always avoid water exposure to all equipment not specifically designed and protected for this purpose. Moisture causes damage to electronics.
- Never place any portion of the model in your mouth as it could cause serious injury or even death.
- Never operate your model with low transmitter batteries.
- Always keep aircraft in sight and under control.
- Always use fully charged batteries.
- Always keep transmitter powered on while aircraft is powered.
- Always remove batteries before disassembly.
- Always keep moving parts clean.
- Always keep parts dry.
- Always let parts cool after use before touching.
- Always remove batteries after use.
- Always ensure failsafe is properly set before flying.
- Never operate aircraft with damaged wiring.
- Never touch moving parts.

Box Contents

Quick Start Information			
Transmitter Setup	Set up your transmitter using the transmitter setup chart		
Elevon Throws		UP	Down
	elevator	15mm	16mm
	aileron	22mm	19mm
Center of Gravity (CG)	Inline with dimples located just in front of finger pockets on bottom of fuselage, slightly nose down when balanced at the dimples.		

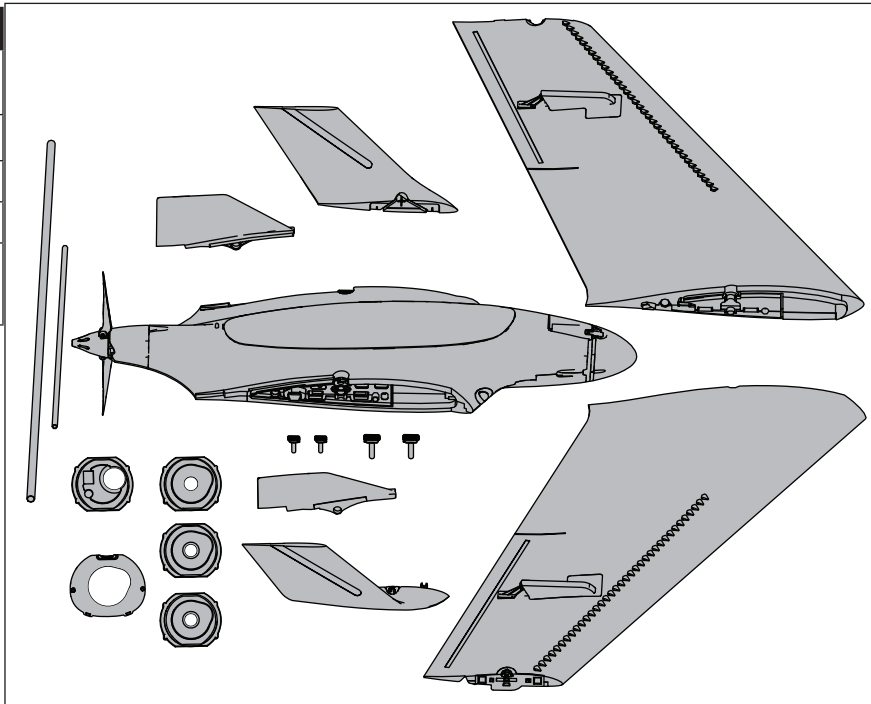

Specifications







		BNF BASIC	PNP PLUG-N-PLAY
	Motor: 10BL Brushless outrunner 1300Kv (EFLM108018)	Installed	Installed
	ESC: 40 A ESC wing (EFLA1040W)	Installed	Installed
	13 gram servo (EFLR7156)	Installed	Installed
	Receiver: Spektrum™ AR636A 6-Channel Sport Receiver (SMPAR636)	Installed	Required to Complete
	Recommended Battery: 11.1V 3S 2200-3200mAh 30C Li-Po (EFLB22003S30 or EFLB32003S30)	Required to Complete	Required to Complete
	Recommended Battery Charger: 3-cell Li-Po battery balancing charger	Required to Complete	Required to Complete
	Recommended Transmitter: Full-Range 6 channel 2.4GHz with Spektrum DSMX® technology	Required to Complete	Required to Complete

Table of Contents

Preflight.....	4
Transmitter Setup	4
Model Assembly	5
Optional Camera Mounts.....	6
Optional Camera Mounts <i>Continued</i>	7
Control Horn and Servo Arm Settings	8
PNP Receiver Selection and Installation	8
Transmitter and Receiver Binding.....	9
Low Voltage Cutoff (LVC)	9
Battery Installation and ESC Arming	10
Center of Gravity (CG)	11
AS3X/SAFE Control Direction Test	11
In Flight Trimming.....	12
Flying Tips and Repairs.....	12
Post Flight	13
Motor Service	13
Troubleshooting Guide AS3X	13
Troubleshooting Guide	14
AMA National Model Aircraft Safety Code.....	15
Limited Warranty	16
Contact Information	17
FCC Information	17
IC Information.....	17
Compliance Information for the European Union.....	17
Replacement Parts.....	63
Optional Parts.....	63

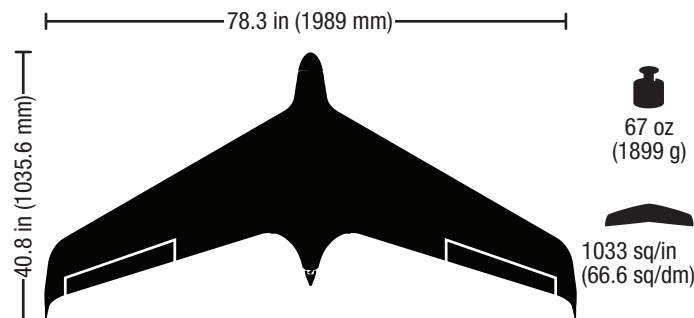

To register your product online, visit www.e-fliterc.com

As of this printing, you are required to register with the FAA if you own this product.
 For up-to-date information on how to register with the FAA, please visit <https://registermyuas.faa.gov/>.
 For additional assistance on regulations and guidance on UAS usage, visit knowbeforeyoufly.org/.

Preflight

1	Remove and inspect contents.
2	Read this instruction manual thoroughly.
3	Charge the flight battery.
4	Setup Transmitter using transmitter setup chart.
5	Fully assemble the airplane.
6	Install the flight battery in the aircraft (once it has been fully charged).
7	Check the Center of Gravity (CG).
8	Bind the aircraft to your transmitter.
9	Make sure linkages move freely.

10	Perform the Control Direction Test with the transmitter.
11	Perform the AS3X Control Direction Test with the aircraft.
12	Adjust flight controls and transmitter.
13	Perform a radio system Range Test.
14	Find a safe open area to fly.
15	Plan flight for flying field conditions.

Transmitter Setup

IMPORTANT: After you set up your model, always rebind the transmitter and receiver to set the desired failsafe positions.

Program Your Transmitter

1. Start with a clean model memory slot.
2. Set the model type to "Airplane."
3. Assign channel 5 (Gear) to a 2-position switch. In the table at right, switch A is used.
4. Leave all other settings at the default values.

Switch A will now control the flight mode function.

- Switch position 0 = Launch (SAFE) Mode
- Switch position 1 = AS3X Mode

If, after flying the aircraft, more or less exponential or dual rate values are desired, those may be adjusted up or down to suit your flying style.

Computerized Transmitter Setup (DX6e, DX6 G2, DX7 G2, DX8 G2, DX9, DX18 and DX20)		
Start all transmitter programming with a blank ACRO model (do a model reset), then name the model.		
Set Dual Rates to:	HIGH 100%	
	LOW 100%	
Set Servo Travel to:	100%	
F-Mode Setup		
Switch 1	Inhibit	
Switch 2	Inhibit	
Channel Assign		
Channel Input Config		
1 Throttle		
2 Aileron		
3 Elevator		
4 Rudder		
5 Gear	Switch A	
6 Aux 1		
Frame Rate		
22mz		
DSMX		
Function List		
Timer		
Mode	Count Down	
Time	8:00	
Start	Throttle Out	
Over	25%	
One Time	Inhibit	

Model Assembly

Wing Installation

1. Slide a winglet (**A**) onto each wing.
2. Secure the winglet into place using the included (smaller sized) locking pin (**B**). Insert the pin and turn it 90 degrees to lock it into place.
3. Slide the front wing tube (short) (**C**) and back wing tube (**D**) into the fuselage.
4. Insert the vertical fin (**E**) into the pocket at the root of the wing (**F**) so the holes align and slide it onto the back wing tube (**D**). The vertical fins should angle outward.
5. Slide the wing onto the front tube.
6. Connect the elevon servo connector (**G**) to the servo connector located in the wing pocket, then slide the wing assembly on the wing tubes until it meets with the fuselage.
7. Attached the opposite vertical fin and wing assembly to the fuselage by sliding them onto the wing tubes.
8. Secure the left and right wing assemblies to the fuselage using the included locking pin (**H**). Insert the pin and turn it 90 degrees to lock into place.

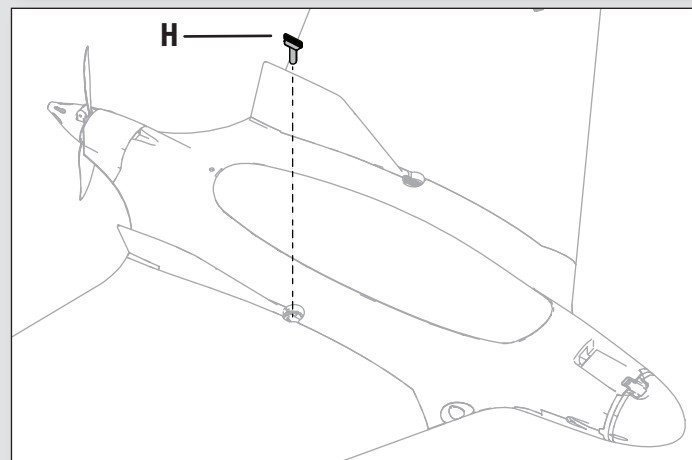
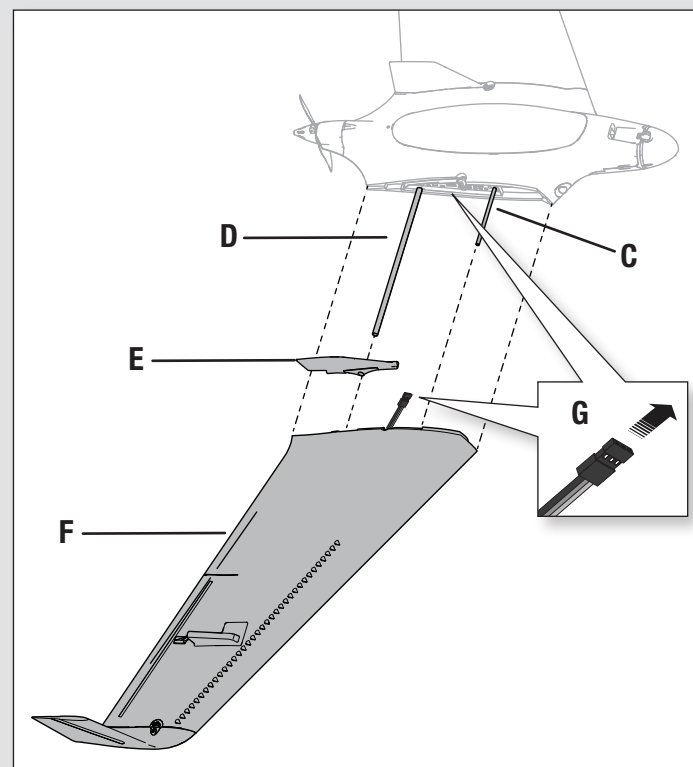
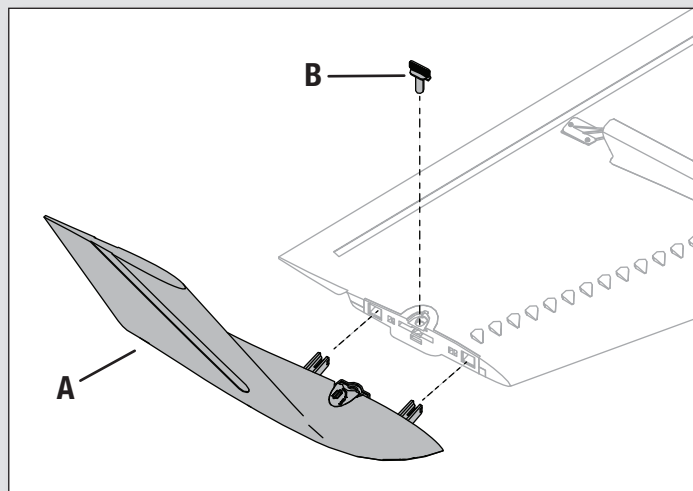

Optional Camera Mounts

Round Nose Removal

1. Remove the 2 screws (A) from each side of the nose cone.
2. Push the tab (B) and rotate the nose down and away from the fuselage.

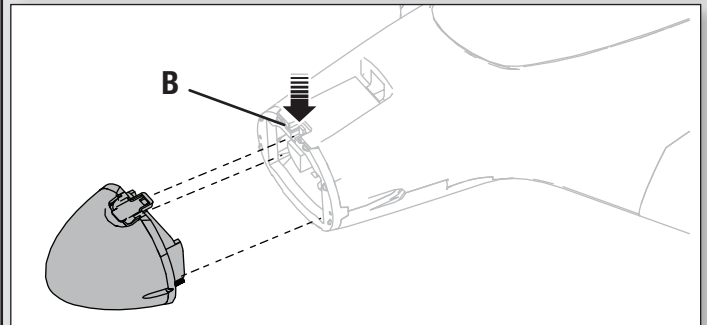
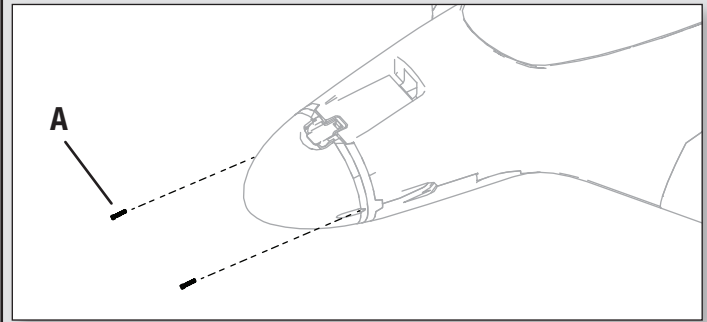

Camera / FPV Camera Installation

The included flat nose allows you to mount various types of cameras. The included foam inserts allow you install many types of cameras, including a GoPro or a Spektrum FPV Camera and many others.

1. Use the included foam inserts (A) to create the correct size pocket for your specific camera.
2. Secure the camera into the pocket with servo tape if desired.
3. If installing a FPV camera, run the wires through the fuselage to the location of the FPV transmitter.
4. Attach the completed flat nose (B) to the front of the fuselage using the included 2 screws.

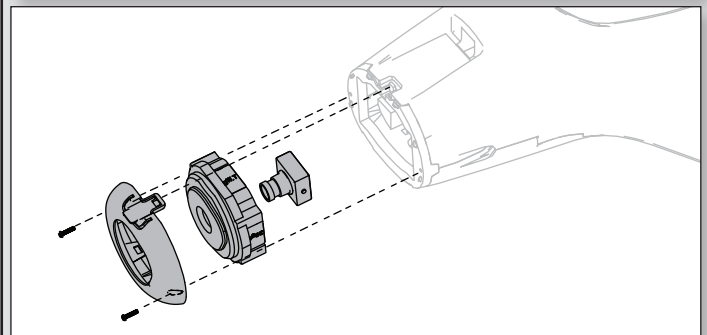
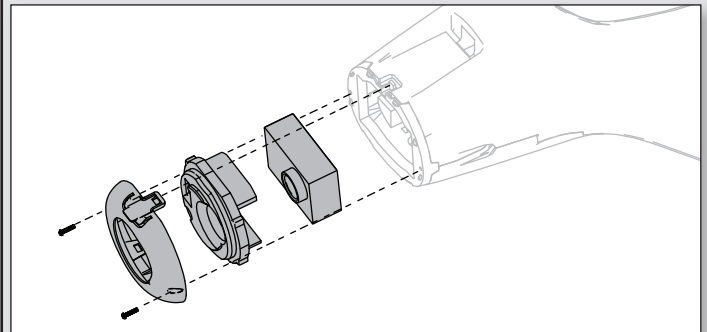

Recommended FPV equipment:

- Camera SPMVC650 or Camera with OSD SPMVC700
- VTX 600MW SPMVT600
- Antenna SPMVX5802
- Power adapter SPMA9556
- Monitor w/ Headset SPMVM430C

Mobius Camera installation.

1. Install a Mobius camera in the flat area on top of the nose.
2. Secure it into place using double sided tape (C).

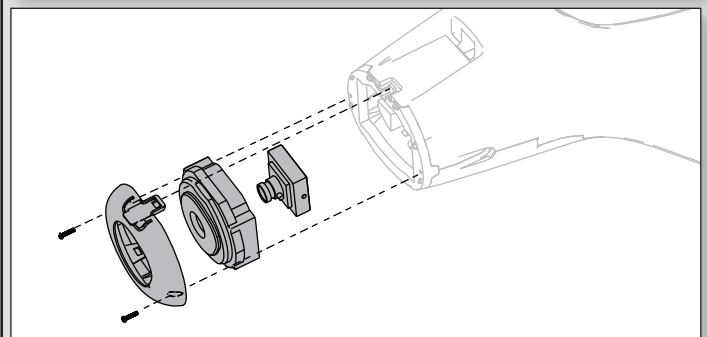
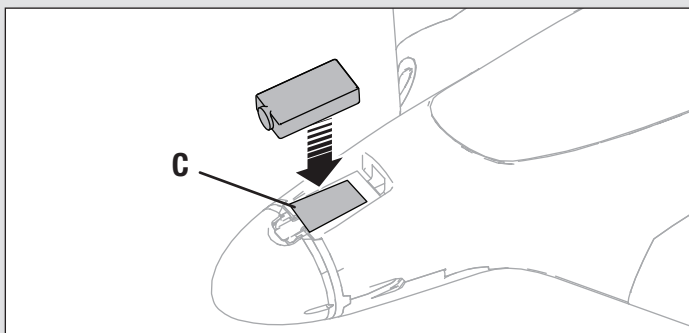

Optional Camera Mounts *Continued*

FPV Transmitter Installation

The FPV transmitter can be installed in the center of the fuselage as shown

1. Remove the canopy hatch from the fuselage.
2. Secure the FPV transmitter into place using hook and loop tape in the location shown.

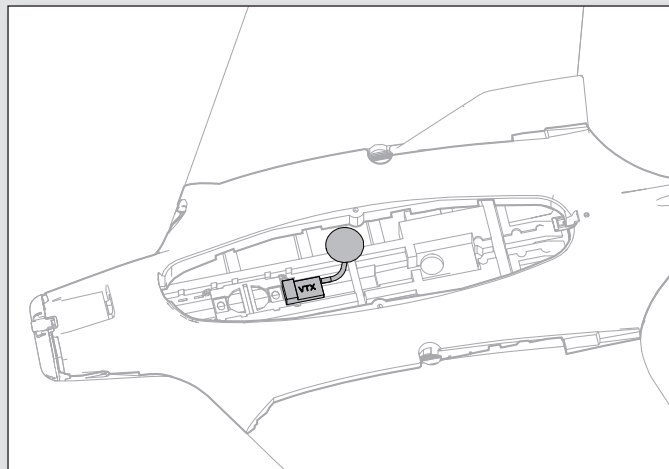

Belly Camera Installation

A GoPro camera can be mounted in the belly of the aircraft using the belly pocket.

1. Push the canopy latch button (A) to release the canopy and remove.
2. Remove the white tape covering the hole for the camera lens in the bottom of the fuselage.
3. Align your GoPro camera with the pocket and install the camera face down as shown.

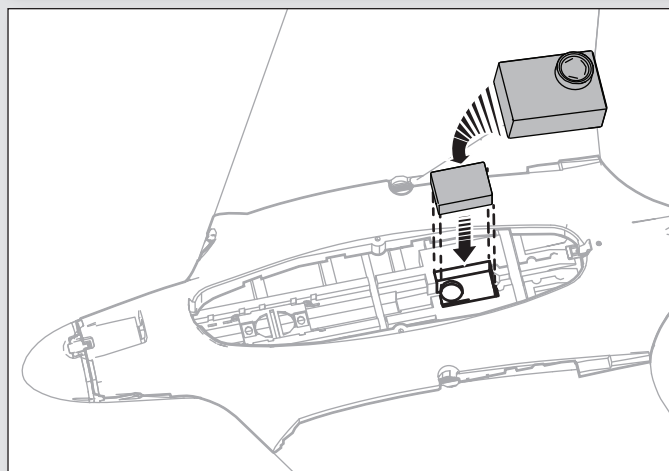
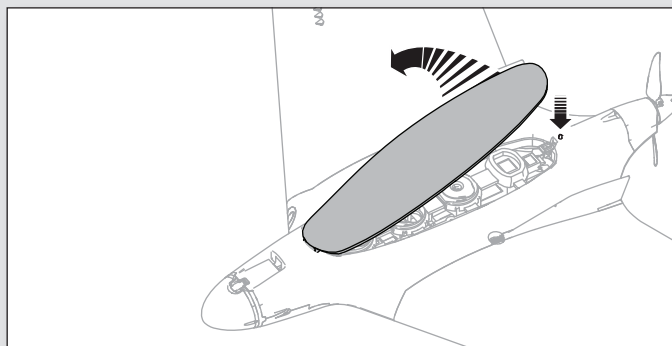

Control Horn and Servo Arm Settings

The table to the right shows the factory settings for the control horns and servo arms. Fly the aircraft at factory settings before making changes.

NOTICE: If control throws are changed from the factory settings, the AR636 gain values may need to be adjusted. Refer to the Spektrum AR636 manual for adjustment of gain values.

After flying, you may choose to adjust the linkage positions for the desired control response. See the table to the right.

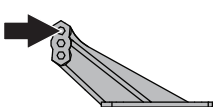
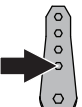
	Horns	Arms
Elevons		

Control Surface Centering

After assembly and transmitter setup, confirm that the control surfaces are centered. Make sure that the trailing edge is 1 mm up from the center; this is the center location for this aircraft. If the control surfaces are not centered, mechanically center the control surfaces by adjusting the linkages.

If adjustment is required, turn the clevis on the linkage to change the length of the linkage between the servo arm and the control horn.

After binding a transmitter to the aircraft receiver, set the trims and sub-trims to 0, then adjust the clevises to center the control surfaces.

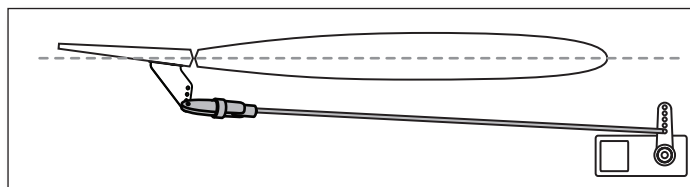

PNP Receiver Selection and Installation

The Spektrum AR636 receiver is recommended for this airplane. If you choose to install another receiver, ensure that it is at least a 3-channel full range (sport) receiver. Refer to your receiver manual for correct installation and operation instructions.

Installation (AR636 shown)

1. Remove the canopy from the fuselage.
2. Mount the receiver parallel to the length of the fuselage as shown. Use double-sided servo tape.

CAUTION: Incorrect installation of the receiver could cause a crash.

3. Attach the appropriate control surfaces to their respective ports on the receiver using the chart in the illustration.

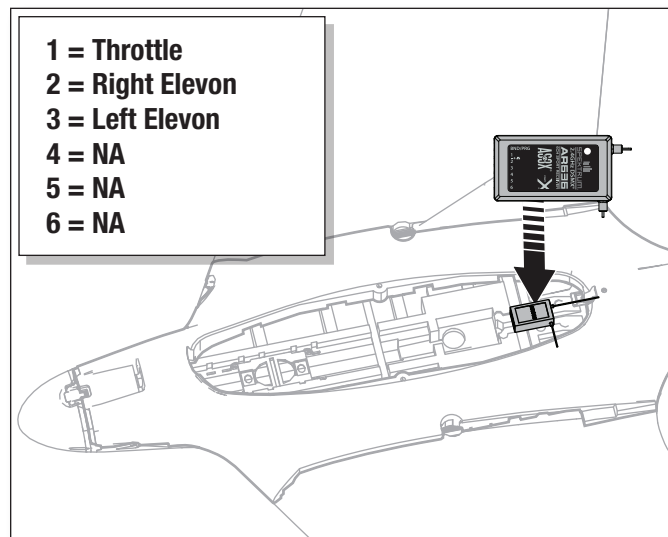

Transmitter and Receiver Binding

Binding is the process of programming the receiver to recognize the GUID (Globally Unique Identifier) code of a single specific transmitter. You need to 'bind' your chosen Spektrum™ DSM2®/DSMX® technology equipped aircraft transmitter to the receiver for proper operation.

IMPORTANT: Before binding a transmitter, read the Transmitter Setup section of this manual to ensure that your transmitter is properly programmed for this aircraft.

Binding Procedure

IMPORTANT: The included AR636 receiver has been programmed for operation specifically for this aircraft. Refer to the receiver manual for correct setup if the receiver is replaced or is used in another aircraft.

Read the transmitter instructions for binding to a receiver (location of transmitter's Bind control). **Please visit www.bindnfly.com for a complete list of compatible transmitters.**

CAUTION: When using a Futaba® transmitter with a Spektrum DSM module, you must reverse the throttle channel and rebind. Refer to your Spektrum module manual for binding and failsafe instructions. Refer to your Futaba transmitter manual for instructions on reversing the throttle channel.

1. Make sure the transmitter is powered off.
2. Move the transmitter controls to neutral (flight controls: rudder, elevators and ailerons) or to low positions (throttle, throttle trim).*
3. Install a bind plug in the receiver bind port.
4. Connect the flight battery to the ESC. The ESC will produce a series of sounds. One long tone, then 3 short tones confirm that the LVC is set correctly for the ESC. The orange bind LED on the receiver will begin to flash rapidly. Make sure the aircraft is upright and level.
5. Power on the transmitter while holding the transmitter bind button or switch. Refer to your transmitter's manual for binding.
6. When the receiver binds to the transmitter, the orange bind light on the receiver will turn solid and the ESC will produce a series of three ascending tones. The tones indicate the ESC is armed, provided the throttle stick and throttle trim are low enough to trigger arming. The aircraft will cycle the control surfaces twice to indicate that the receiver has initialized.

7. Remove the bind plug from the bind port.
8. Safely store the bind plug (some owners attach the bind plug to their transmitter using two-part loops and clips).
9. The receiver should retain the binding instructions received from the transmitter until another binding is done.

* The throttle will not arm if the transmitter's throttle control is not put at the lowest position. If you encounter problems, follow the binding instructions and refer to the transmitter troubleshooting guide for other instructions. If needed, contact the appropriate Horizon Product Support office.

**Failsafe

If the receiver loses transmitter communication, the failsafe will activate. When activated, failsafe moves the throttle channel to its preset failsafe position (low throttle) that was set during binding. All other channels hold their last position.

Bind Plug Installation

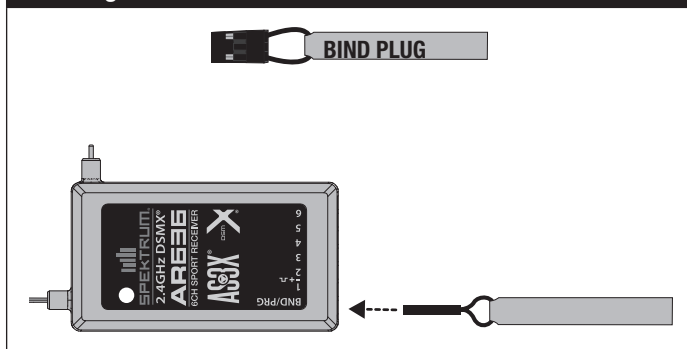

Low Voltage Cutoff (LVC)

When a Li-Po battery is discharged below 3V per cell, it will not hold a charge. The ESC protects the flight battery from over-discharge using Low Voltage Cutoff (LVC). Before the battery charge decreases too much, LVC removes power supplied to the motor. Power to the motor pulses, showing that some battery power is reserved for flight control and safe landing.

Disconnect and remove the Li-Po battery from the aircraft after use to prevent trickle discharge. Charge your Li-Po battery to about half capacity before storage. During storage, make sure the battery charge does not fall below 3V per cell. LVC does not prevent the battery from over-discharge during storage.

NOTICE: Repeated flying to LVC will damage the battery.

Tip: Monitor your aircraft battery's voltage before and after flying by using a Li-Po Cell Voltage Checker (EFLA111, sold separately).

Battery Installation and ESC Arming

Battery Selection

We recommend the E-flite® 2200-3200mAh 11.1V 3S 30C Li-Po battery (EFLB32003S30). If using a battery other than those listed, the battery should be within the range of capacity, dimensions and weight of the E-flite Li-Po battery packs to fit in the fuselage. Be sure the model balances at the recommended CG.

1. Lower the throttle and throttle trim to the lowest settings. Power on the Transmitter, then wait 5 seconds.
2. Push the canopy latch button (A) to release the canopy and remove.
3. For added security apply the loop side (soft side) of the optional hook and loop tape (B) to the bottom of your battery and the hook side to the battery compartment.
4. Install a fully charged 2200mAh battery (C) all the way forward in the battery compartment as shown.

IMPORTANT If you are flying with an FPV camera in the nose only, a 3200mAh battery must be used to achieve proper CG. Adjust the battery position for proper CG accordingly.

5. Connect the battery to the ESC. (the ESC is now armed).
6. Keep the aircraft immobile, upright and level, and away from wind or the system will not initialize.
 - The ESC will sound a series of tones (refer to step 6 of the binding instructions for more information).
 - An LED will light on the receiver.
 - The elevons will cycle up and down two times to indicate that the aircraft has initialized.

If the ESC sounds a continuous double beep after the flight battery is connected, recharge or replace the battery.

7. Reinstall the canopy by inserting the front tab first and pushing down on the back of the canopy until the latch locks.

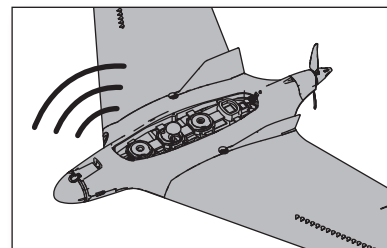
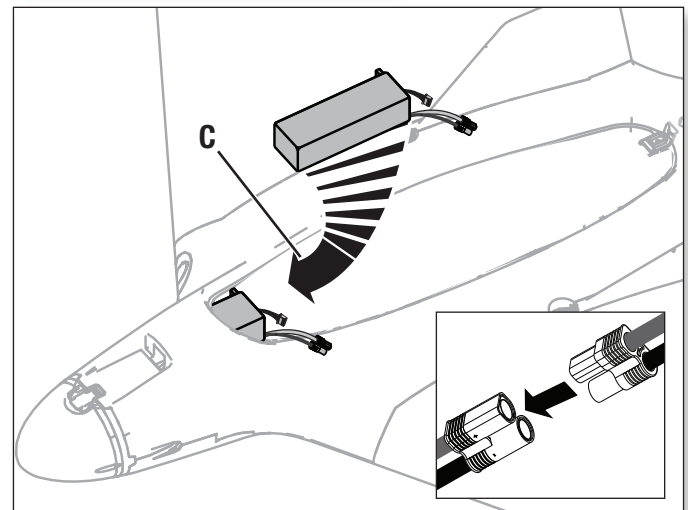
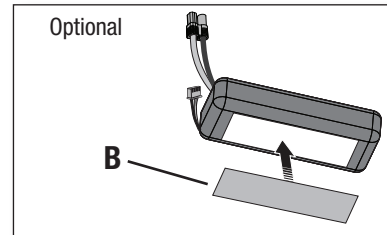
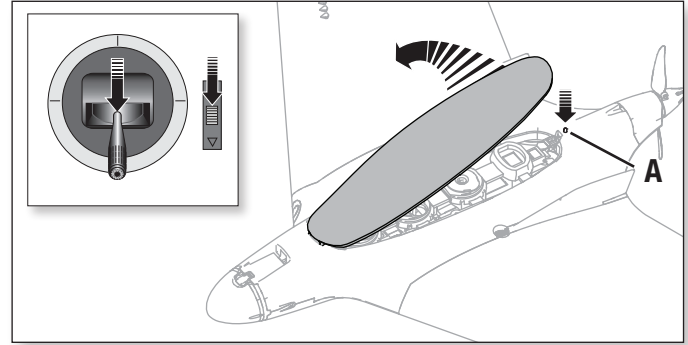

CAUTION: Always keep hands away from the propeller. When armed, the motor will turn the propeller in response to any throttle movement.

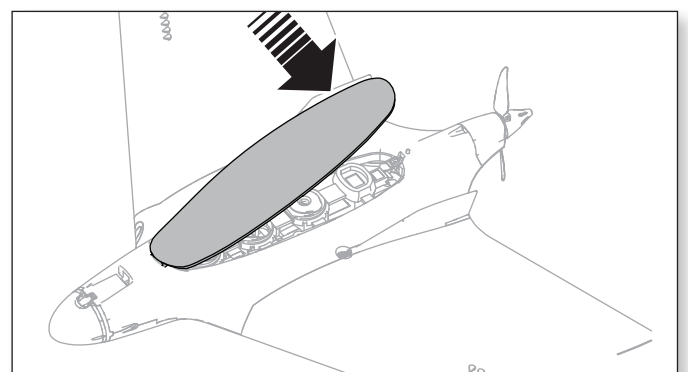

Center of Gravity (CG)

Establishing the correct center of gravity (CG) is very important for a successful flight experience with this aircraft. The correct CG location is identified by the molded dimples just in front of the finger pockets on the bottom of the aircraft. The aircraft will balance slightly nose down at this location.

This CG location has been determined with the recommended Li-Po battery (EFLB22003S30) installed all the way forward in the battery tray.

There is built in ballast in the nose, so no additional weight is required for proper CG.

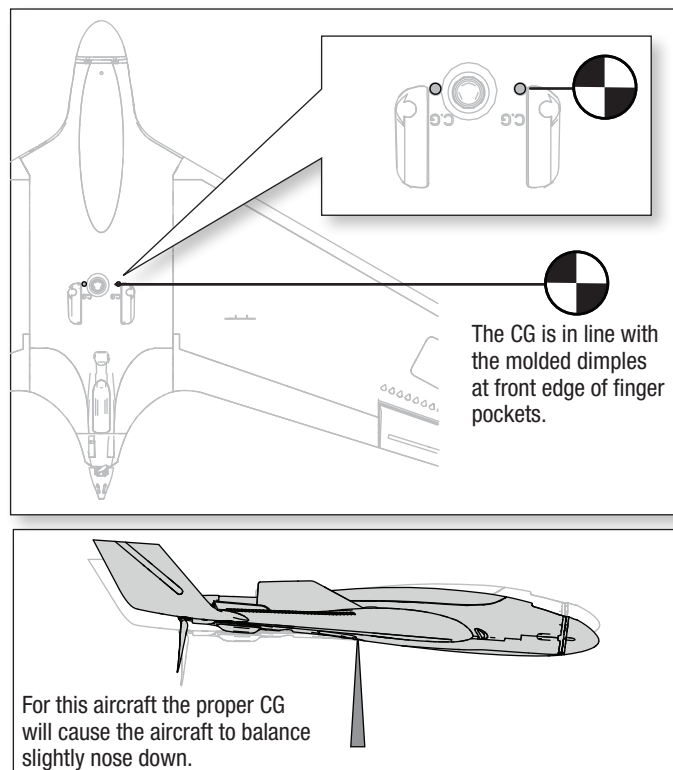

AS3X/SAFE Control Direction Test

This test ensures that the AS3X® control system is functioning properly. Assemble the aircraft and bind your transmitter to the receiver before performing this test.

1. Flip transmitter switch A to SAFE mode.

CAUTION: Keep all body parts, hair and loose clothing away from a moving propeller, as these items could become entangled.

2. Move the entire aircraft as shown and ensure the control surfaces move in the direction indicated in the graphic. If the control surfaces do not respond as shown, do not fly the aircraft. Refer to the receiver manual for more information.

Once the AS3X system is active, control surfaces may move rapidly. This is normal. AS3X remains active until the battery is disconnected.

	Aircraft movement	AS3X Reaction
Pitch		
Roll		

In Flight Trimming

During your first flight, trim the aircraft for level flight in a glide (power off). Make small trim adjustments with your transmitter's trim switches to straighten the aircraft's flight path.

After adjusting trim do not touch the control sticks for 3 seconds. This allows the receiver to learn the correct settings to optimize AS3X performance.

Failure to do so could affect flight performance.

It is normal for the aircraft to climb under power when it's trimmed properly for maximum glide performance.

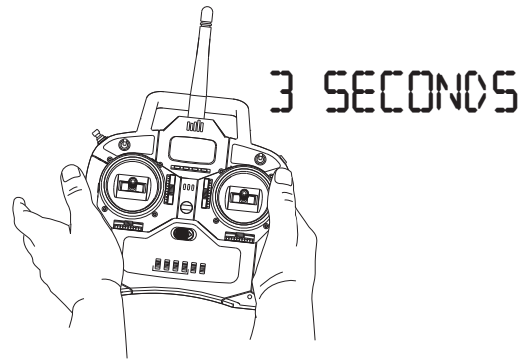

Flying Tips and Repairs

Consult local laws and ordinances before choosing a flying location.

Range Check your Radio System

Before you fly, range check the radio system. Refer to your specific transmitter instruction manual for range test information.

Oscillation

Once the AS3X system is active (after advancing the throttle for the first time), you will normally see the control surfaces react to aircraft movement. In some flight conditions you may see oscillation (the aircraft rocks back and forth on one axis due to overcontrol). If oscillation occurs, refer to the Troubleshooting Guide for more information.

Hand Launching

When hand-launching your aircraft:

1. Put the aircraft into launch mode with the channel 5 switch.
2. Hold the aircraft in one hand and the transmitter in the other.
3. Apply full throttle and throw the aircraft directly into the wind, angled slightly up (5 to 10 degrees above the horizon).
4. Climb to a safe altitude and check the trim.

Flying

Once your aircraft is at a safe altitude, flip the gear switch to put the aircraft into AS3X mode to check and adjust the trim of the aircraft. Adjust the trim as needed so that the aircraft flies straight and level without input from the transmitter. Once the trim is adjusted, begin exploring the flight envelope of the aircraft.

Your aircraft can fly for prolonged periods of time when using conservative throttle management.



CAUTION: Do not dive the aircraft for prolonged periods of time. Doing so could cause the aircraft to gain too much speed, and overstress of the aircraft is possible.

Spin Recovery

Sometimes the aircraft can fall into a spin. Knowing how to recover this aircraft from a spin before flying is recommended.

1. Make sure the aircraft is in AS3X mode and not in launch mode.
2. Let the aileron stick go neutral.
3. Apply full down elevator until rotation of the aircraft stops.
4. Apply up elevator to restore level flight.

Landing

Land into the wind. Due to the high lifting efficiency of this aircraft's airfoil design, landing requires a large landing area clear of trees, buildings and cars. While on your downwind leg, remember that this glides much better than other aircraft.

You may need to setup for landing lower and with a more shallow decent than you may be used to. As you are on approach for landing, ensure that the model is descending slowly, but also not accelerating. If the model is accelerating, it is likely that you will overshoot your projected landing area.

Maintain this descent and speed, and, as the model nears the ground (approximately 6 inches (15 cm)), slowly apply a small amount of up elevator. The model should level out and fly parallel to the ground, decelerating further. Be sure the model does not climb. As it decelerates, keep flying the model parallel to the ground until it comes to rest gently on its belly.

NOTICE: If a crash is imminent, reduce the throttle fully. Failure to do so could result in extra damage to the airframe, as well as damage to the ESC and motor.

NOTICE: Crash damage is not covered under warranty.

Repairs

Repair this aircraft using CA (cyanoacrylate adhesive) glue or clear tape.

When parts are not repairable, see the Replacement Parts List for ordering by item number.

For a listing of all replacement and optional parts, refer to the list at the back of this manual.

NOTICE: When you are finished flying, never leave the aircraft in direct sunlight or in a hot, enclosed area such as a car. Doing so can damage the foam.

Post Flight

1	Disconnect the flight battery from the ESC (Required for Safety and battery life).
2	Power OFF the transmitter.
3	Remove the flight battery from the aircraft.
4	Recharge the flight battery.

5	Repair or replace all damaged parts.
6	Store the flight battery apart from the aircraft and monitor the battery charge.
7	Make note of the flight conditions and flight plan results, planning for future flights.

Motor Service

CAUTION: Always disconnect the flight battery before performing motor service.

Disassembly

1. Remove the screw (A) and spinner (B) from the cullet (C).
2. Use a tool to loosen and remove the prop nut (D).
3. Remove the Propeller assembly (E), propeller hub (F) and the cullet from the motor shaft.
4. Remove the nut (G) and screw (H) to remove the propeller blades from the propeller assembly.
5. Remove the 4 screws (I) from the motor mount (J).
6. Disconnect the motor wires from the ESC wires.
7. Remove the motor (K) and motor mount from the fuselage.
8. Remove the 4 screws (L) and motor mount from the motor.

Assembly

Assemble in reverse order.

- Correctly align and connect the motor wire colors with the ESC wires.
- Install the propeller with the molded numbers facing towards the nose of the aircraft.
- A tool is required to tighten the lock nut on the prop adapter.

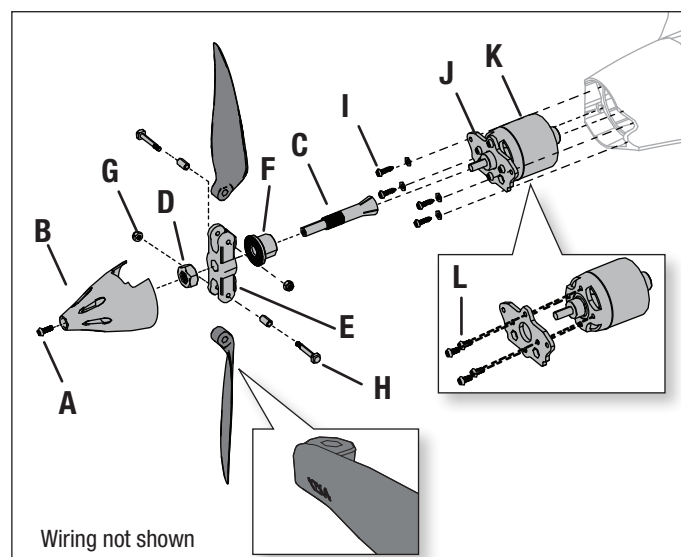

Troubleshooting Guide AS3X

Problem	Possible Cause	Solution
Oscillation	Damaged propeller or spinner	Replace propeller or spinner
	Imbalanced propeller	Balance the propeller. For more information, view John Redman's propeller balancing video at www.horizon-hobby.com
	Motor vibration	Replace parts or correctly align all parts and tighten fasteners as needed
	Loose receiver	Align and secure receiver in fuselage
	Loose aircraft controls	Tighten or otherwise secure parts (servo, arm, linkage, horn and control surface)
	Worn parts	Replace worn parts (especially propeller, spinner or servo)
Inconsistent flight performance	Irregular servo movement	Replace servo
	Trim is not at neutral	If you adjust trim more than 8 clicks, adjust the clevis to remove trim
	Sub-Trim is not at neutral	No Sub-Trim is allowed. Adjust the servo linkage
Incorrect response to the AS3X Control Direction Test	Aircraft was not kept immobile for 5 seconds after battery connection	With the throttle stick in lowest position. Disconnect battery, then reconnect battery and keep the aircraft still for 5 seconds
	Incorrect direction settings in the receiver, which can cause a crash	DO NOT fly. Correct the direction settings (refer to the receiver manual), then fly

Troubleshooting Guide

Problem	Possible Cause	Solution
Aircraft will not re- spond to throttle but responds to other controls	Throttle not at idle and/or throttle trim too high	Reset controls with throttle stick and throttle trim at lowest setting
	Throttle servo travel is lower than 100%	Make sure throttle servo travel is 100% or greater
	Throttle channel is reversed	Reverse throttle channel on transmitter
	Motor disconnected from ESC	Make sure motor is connected to the ESC
Extra propeller noise or extra vibration	Damaged propeller and spinner, collet or motor	Replace damaged parts
	Propeller is out of balance	Balance or replace propeller
	Prop nut is too loose	Tighten the prop nut
Reduced flight time or aircraft under- powered	Flight battery charge is low	Completely recharge flight battery
	Propeller installed backwards	Install propeller with numbers facing forward
	Flight battery damaged	Replace flight battery and follow flight battery instructions
	Flight conditions may be too cold	Make sure battery is warm before use
	Battery capacity too low for flight conditions	Replace battery or use a larger capacity battery
Aircraft will not Bind (during binding) to transmitter	Transmitter too near aircraft during binding process	Move powered transmitter a few feet from aircraft, disconnect and reconnect flight battery to aircraft
	Aircraft or transmitter is too close to large metal object, wireless source or another transmitter	Move aircraft and transmitter to another location and attempt binding again
	The bind plug is not installed correctly in the bind port	Install bind plug in bind port and bind the aircraft to the transmitter
	Flight battery/transmitter battery charge is too low	Replace/recharge batteries
	Bind switch or button not held long enough during bind process	Power off transmitter and repeat bind process. Hold transmitter bind button or switch until receiver is bound
Aircraft will not con- nect (after binding) to transmitter	Transmitter too near aircraft during connecting process	Move powered transmitter a few feet from aircraft, disconnect and reconnect flight battery to aircraft
	Aircraft is not upright and level when powered on	Make sure aircraft is up right and level then power on
	Aircraft or transmitter is too close to large metal object, wireless source or another transmitter	Move aircraft and transmitter to another location and attempt connecting again
	Bind plug left installed in bind port	Rebind transmitter to the aircraft and remove the bind plug before cycling power
	Aircraft bound to different model memory (ModelMatch™ radios only)	Select correct model memory on transmitter
	Flight battery/Transmitter battery charge is too low	Replace/recharge batteries
	Transmitter may have been bound to a different aircraft using different DSM protocol	Bind aircraft to transmitter
Control surface does not move	Control surface, control horn, linkage or servo damage	Replace or repair damaged parts and adjust controls
	Wire damaged or connections loose	Do a check of wires and connections, connect or replace as needed
	Transmitter is not bound correctly or the incorrect airplanes was selected	Re-bind or select correct airplanes in transmitter
	Flight battery charge is low	Fully recharge flight battery
	BEC (Battery Elimination Circuit) of the ESC is damaged	Replace ESC
Controls reversed	Transmitter settings are reversed	Perform the Control Direction Test and adjust the controls on transmitter appropriately
Motor power pulses then motor loses power	ESC uses default soft Low Voltage Cutoff (LVC)	Recharge flight battery or replace battery that is no longer performing
	Weather conditions might be too cold	Postpone flight until weather is warmer
	Battery is old, worn out, or damaged	Replace battery
	Battery C rating might be too small	Use recommended battery

AMA National Model Aircraft Safety Code

Effective January 1, 2014

A. GENERAL

A model aircraft is a non-human-carrying aircraft capable of sustained flight in the atmosphere. It may not exceed limitations of this code and is intended exclusively for sport, recreation, education and/or competition. All model flights must be conducted in accordance with this safety code and any additional rules specific to the flying site.

1. Model aircraft will not be flown:
 - (a) In a careless or reckless manner.
 - (b) At a location where model aircraft activities are prohibited.
2. Model aircraft pilots will:
 - (a) Yield the right of way to all man carrying aircraft.
 - (b) See and avoid all aircraft and a spotter must be used when appropriate. (AMA Document #540-D.)
 - (c) Not fly higher than approximately 400 feet above ground level within three (3) miles of an airport, without notifying the airport operator.
 - (d) Not interfere with operations and traffic patterns at any airport, heliport or seaplane base except where there is a mixed use agreement.
 - (e) Not exceed a takeoff weight, including fuel, of 55 pounds unless in compliance with the AMA Large Model Aircraft program. (AMA Document 520-A.)
 - (f) Ensure the aircraft is identified with the name and address or AMA number of the owner on the inside or affixed to the outside of the model aircraft. (This does not apply to model aircraft flown indoors).
 - (g) Not operate aircraft with metal-blade propellers or with gaseous boosts except for helicopters operated under the provisions of AMA Document #555.
 - (h) Not operate model aircraft while under the influence of alcohol or while using any drug which could adversely affect the pilot's ability to safely control the model.
 - (i) Not operate model aircraft carrying pyrotechnic devices which explode or burn, or any device which propels a projectile or drops any object that creates a hazard to persons or property.

Exceptions:

 - Free Flight fuses or devices that burn producing smoke and are securely attached to the model aircraft during flight.
 - Rocket motors (using solid propellant) up to a G-series size may be used provided they remain attached to the model during flight. Model rockets may be flown in accordance with the National Model Rocketry Safety Code but may not be launched from model aircraft.
 - Officially designated AMA Air Show Teams (AST) are authorized to use devices and practices as defined within the Team AMA Program Document (AMA Document #718).
 - (j) Not operate a turbine-powered aircraft, unless in compliance with the AMA turbine regulations. (AMA Document #510-A).
3. Model aircraft will not be flown in AMA sanctioned events, air shows or model demonstrations unless:
 - (a) The aircraft, control system and pilot skills have successfully demonstrated all maneuvers intended or anticipated prior to the specific event.
 - (b) An inexperienced pilot is assisted by an experienced pilot.
4. When and where required by rule, helmets must be properly worn and fastened. They must be OSHA, DOT, ANSI, SNELL or NOCSAE approved or comply with comparable standards.

B. RADIO CONTROL

1. All pilots shall avoid flying directly over unprotected people, vessels, vehicles or structures and shall avoid endangerment of life and property of others.
2. A successful radio equipment ground-range check in accordance with manufacturer's recommendations will be completed before the first flight of a new or repaired model aircraft.
3. At all flying sites a safety line(s) must be established in front of which all flying takes place (AMA Document #706.)
 - (a) Only personnel associated with flying the model aircraft are allowed at or in front of the safety line.
 - (b) At air shows or demonstrations, a straight safety line must be established.
 - (c) An area away from the safety line must be maintained for spectators.
 - (d) Intentional flying behind the safety line is prohibited.
4. RC model aircraft must use the radio-control frequencies currently allowed by the Federal Communications Commission (FCC). Only individuals properly licensed by the FCC are authorized to operate equipment on Amateur Band frequencies.
5. RC model aircraft will not operate within three (3) miles of any pre-existing flying site without a frequency-management agreement (AMA Documents #922 and #923.)
6. With the exception of events flown under official AMA Competition Regulations, excluding takeoff and landing, no powered model may be flown outdoors closer than 25 feet to any individual, except for the pilot and the pilot's helper(s) located at the flight line.
7. Under no circumstances may a pilot or other person touch a model aircraft in flight while it is still under power, except to divert it from striking an individual.
8. RC night flying requires a lighting system providing the pilot with a clear view of the model's attitude and orientation at all times. Hand-held illumination systems are inadequate for night flying operations.
9. The pilot of a RC model aircraft shall:
 - (a) Maintain control during the entire flight, maintaining visual contact without enhancement other than by corrective lenses prescribed for the pilot.
 - (b) Fly using the assistance of a camera or First-Person View (FPV) only in accordance with the procedures outlined in AMA Document #550.
 - (c) Fly using the assistance of autopilot or stabilization system only in accordance with the procedures outlined in AMA Document #560.

Please see your local or regional modeling association's guidelines for proper, safe operation of your model aircraft.

Limited Warranty

What this Warranty Covers

Horizon Hobby, LLC, (Horizon) warrants to the original purchaser that the product purchased (the "Product") will be free from defects in materials and workmanship at the date of purchase.

What is Not Covered

This warranty is not transferable and does not cover (i) cosmetic damage, (ii) damage due to acts of God, accident, misuse, abuse, negligence, commercial use, or due to improper use, installation, operation or maintenance, (iii) modification of or to any part of the Product, (iv) attempted service by anyone other than a Horizon Hobby authorized service center, (v) Product not purchased from an authorized Horizon dealer, or (vi) Product not compliant with applicable technical regulations, or (vii) use that violates any applicable laws, rules, or regulations.

OTHER THAN THE EXPRESS WARRANTY ABOVE, HORIZON MAKES NO OTHER WARRANTY OR REPRESENTATION, AND HEREBY DISCLAIMS ANY AND ALL IMPLIED WARRANTIES OF NON-INFRINGEMENT, MERCHANTABILITY AND FITNESS FOR A PARTICULAR PURPOSE. THE PURCHASER ACKNOWLEDGES THAT THEY ALONE HAVE DETERMINED THAT THE PRODUCT WILL SUITABLY MEET THE REQUIREMENTS OF THE PURCHASER'S INTENDED USE.

Purchaser's Remedy

Horizon's sole obligation and purchaser's sole and exclusive remedy shall be that Horizon will, at its option, either (i) service, or (ii) replace, any Product determined by Horizon to be defective. Horizon reserves the right to inspect any and all Product(s) involved in a warranty claim. Service or replacement decisions are at the sole discretion of Horizon. Proof of purchase is required for all warranty claims. SERVICE OR REPLACEMENT AS PROVIDED UNDER THIS WARRANTY IS THE PURCHASER'S SOLE AND EXCLUSIVE REMEDY.

Limitation of Liability

HORIZON SHALL NOT BE LIABLE FOR SPECIAL, INDIRECT, INCIDENTAL OR CONSEQUENTIAL DAMAGES, LOSS OF PROFITS OR PRODUCTION OR COMMERCIAL LOSS IN ANY WAY, REGARDLESS OF WHETHER SUCH CLAIM IS BASED IN CONTRACT, WARRANTY, TORT, NEGLIGENCE, STRICT LIABILITY OR ANY OTHER THEORY OF LIABILITY, EVEN IF HORIZON HAS BEEN ADVISED OF THE POSSIBILITY OF SUCH DAMAGES. Further, in no event shall the liability of Horizon exceed the individual price of the Product on which liability is asserted. As Horizon has no control over use, setup, final assembly, modification or misuse, no liability shall be assumed nor accepted for any resulting damage or injury. By the act of use, setup or assembly, the user accepts all resulting liability. If you as the purchaser or user are not prepared to accept the liability associated with the use of the Product, purchaser is advised to return the Product immediately in new and unused condition to the place of purchase.

Law

These terms are governed by Illinois law (without regard to conflict of law principals). This warranty gives you specific legal rights, and you may also have other rights which vary from state to state. Horizon reserves the right to change or modify this warranty at any time without notice.

WARRANTY SERVICES

Questions, Assistance, and Services

Your local hobby store and/or place of purchase cannot provide warranty support or service. Once assembly, setup or use of the Product has been started, you must contact your local distributor or Horizon directly. This will enable Horizon to better answer your questions and service you in the event that you may need any assistance. For questions or assistance, please visit our website at www.horizonhobby.com, submit a Product Support Inquiry, or call the toll free telephone number referenced in the Warranty and Service Contact Information section to speak with a Product Support representative.

Inspection or Services

If this Product needs to be inspected or serviced and is compliant in the country you live and use the Product in, please use the Horizon Online Service Request submission process found on our website or call Horizon to obtain a Return Merchandise Authorization (RMA) number. Pack the Product securely using a shipping carton. Please note that original boxes may be included, but are not designed to withstand the rigors of shipping without additional

protection. Ship via a carrier that provides tracking and insurance for lost or damaged parcels, as Horizon is not responsible for merchandise until it arrives and is accepted at our facility. An Online Service Request is available at http://www.horizonhobby.com/content/_service-center_render-service-center. If you do not have internet access, please contact Horizon Product Support to obtain a RMA number along with instructions for submitting your product for service. When calling Horizon, you will be asked to provide your complete name, street address, email address and phone number where you can be reached during business hours. When sending product into Horizon, please include your RMA number, a list of the included items, and a brief summary of the problem. A copy of your original sales receipt must be included for warranty consideration. Be sure your name, address, and RMA number are clearly written on the outside of the shipping carton.

NOTICE: Do not ship LiPo batteries to Horizon. If you have any issue with a LiPo battery, please contact the appropriate Horizon Product Support office.

Warranty Requirements

For Warranty consideration, you must include your original sales receipt verifying the proof-of-purchase date. Provided warranty conditions have been met, your Product will be serviced or replaced free of charge. Service or replacement decisions are at the sole discretion of Horizon.

Non-Warranty Service

Should your service not be covered by warranty, service will be completed and payment will be required without notification or estimate of the expense unless the expense exceeds 50% of the retail purchase cost. By submitting the item for service you are agreeing to payment of the service without notification. Service estimates are available upon request. You must include this request with your item submitted for service. Non-warranty service estimates will be billed a minimum of ½ hour of labor. In addition you will be billed for return freight. Horizon accepts money orders and cashier's checks, as well as Visa, MasterCard, American Express, and Discover cards. By submitting any item to Horizon for service, you are agreeing to Horizon's Terms and Conditions found on our website http://www.horizonhobby.com/content/_service-center_render-service-center.

ATTENTION: Horizon service is limited to Product compliant in the country of use and ownership. If received, a non-compliant Product will not be serviced. Further, the sender will be responsible for arranging return shipment of the un-serviced Product, through a carrier of the sender's choice and at the sender's expense. Horizon will hold non-compliant Product for a period of 60 days from notification, after which it will be discarded.

Contact Information

Country of Purchase	Horizon Hobby	Phone Number/Email Address	Address
United States of America	Horizon Service Center (Repairs and Repair Requests)	servicecenter.horizonhobby.com/ RequestForm/	4105 Fieldstone Rd Champaign, Illinois, 61822 USA
	Horizon Product Support (Product Technical Assistance)	productsupport@horizonhobby. com. 877-504-0233	
	Sales	websales@horizonhobby.com 800-338-4639	
United Kingdom	Service/Parts/Sales: Horizon Hobby Limited	sales@horizonhobby.co.uk +44 (0) 1279 641 097	Units 1–4 , Ployters Rd, Staple Tye Harlow, Essex, CM18 7NS, United Kingdom
		Horizon Technischer Service Sales: Horizon Hobby GmbH	
Germany	Service/Parts/Sales: Horizon Hobby SAS	infosfrance@horizonhobby.com +33 (0) 1 60 18 34 90	11 Rue Georges Charpak 77127 Lieusaint, France
		Horizon Technischer Service Sales: Horizon Hobby GmbH	
France	Service/Parts/Sales: Horizon Hobby SAS	infosfrance@horizonhobby.com +33 (0) 1 60 18 34 90	11 Rue Georges Charpak 77127 Lieusaint, France



FCC Information

FCC ID: BRWDASRX15

Operation is subject to the following two conditions: (1) This device may not cause harmful interference, and (2) this device must accept any interference received, including interference that may cause undesired operation.

CAUTION: Changes or modifications not expressly approved by the party responsible for compliance could void the user's authority to operate the equipment.

This product contains a radio transmitter with wireless technology which has been tested and found to be compliant with the applicable regulations governing a radio transmitter in the 2.400GHz to 2.4835GHz frequency range.

IC Information

IC ID: 6157A-AMRX15

This device complies with Industry Canada licence-exempt RSS standard(s). Operation is subject to the following two conditions: (1) this device may not cause interference, and (2) this device must accept any interference, including interference that may cause undesired operation of the device.

Compliance Information for the European Union

EFL Opterra BNF Basic (EFL11150)

EU Compliance Statement: Horizon Hobby, LLC hereby declares that this product is in compliance with the essential requirements and other relevant provisions of the R&TTE and EMC Directive.

EFL Opterra PNP (EFL11175)

EU Compliance Statement: Horizon Hobby, LLC hereby declares that this product is in compliance with the essential requirements and other relevant provisions of the EMC Directive.

A copy of the EU Declaration of Conformity is available online at: <http://www.horizonhobby.com/content/support-render-compliance>.

Instructions for disposal of WEEE by users in the European Union



This product must not be disposed of with other waste. Instead, it is the user's responsibility to dispose of their waste equipment by handing it over to a designated collections point for the recycling of waste electrical and electronic equipment. The separate collection and recycling of your waste equipment at the time of disposal will help to conserve natural resources and ensure that it is recycled in a manner that protects human health and the environment. For more information about where you can drop off your waste equipment for recycling, please contact your local city office, your household waste disposal service or where you purchased the product.

Replacement Parts • Ersatzteile • Pièces de rechange • Pezzi di ricambio

Part # Nummer Numéro Codice	Description	Beschreibung	Description	Descrizione
EFL11101	Foam Nose: Opterra	Schaumnase: Opterra	Opterra - Nez en mousse	Punta anteriore in espanso: Opterra
EFL11102	Camera Nose: Opterra	Kameranase: Opterra	Opterra - Nez pour caméra	Punta anteriore con alloggi. video-camera: Opterra
EFL11105	Folding Prop/Spinner: Opterra	Faltpropeller/Spinner: Opterra	Opterra - Hélice pliable/cône	Elica ripiegabile/ogiva: Opterra
EFL11106	Motor Mount: Opterra	Motorhalterung: Opterra	Opterra - Support moteur	Supporto motore: Opterra
EFL11108	Horn/Pushrod Set: Opterra	Horn-/Gestängesatz: Opterra	Opterra - Tringlerie/guignol	Set squadrette/aste di comando: Opterra
EFL11110	Center Fin Set (2): Opterra	Mittleres Seitenleitwerk-Satz (2): Opterra	Opterra - Dérive centrale (2)	Set pinne centrali (2): Opterra
EFL11111	Winglet Set (2): Opterra	Winglet-Satz (2): Opterra	Opterra - Winglets (2)	Set winglet (2): Opterra
EFL11112	Thumb Screw Set: Opterra	Daumenschraubensatz: Opterra	Opterra - Vis de fixation	Set viti ad aletta: Opterra
EFL11119	Carbon Tube Set (2): Opterra	Carbonrohersatz (2): Opterra	Opterra - Clé d'aile en carbone (2)	Set baionette in carbonio (2): Opterra
EFL11120	Complete Wing Set: Opterra	Kompletter Flügelsatz: Opterra	Opterra - Aile complète	Set ala completa: Opterra
EFL11167	Fuselage w/parts: Opterra	Rumpf mit Bauteilen: Opterra	Opterra - Fuselage avec pièces	Fusoliera con parti: Opterra
EFLM108018	BL10 Brushless Outrunner 1300Kv	BL10 Bürstenloser Außenläufer 1300 kV	Moteur Brushless BL10, 1300Kv à cage tournante	Motore outrunner brushless BL10 1300 Kv
EFLA1040W	40 AMP BL ESC: Opterra	40 AMP BL GESCHWINDIG-KEITSREGLER:	Opterra - Contrôleur Brushless 40A	ESC BL 40 A: Opterra
EFLR7156	13G Digital Servo	13G Digitaler Servo	Servo digital 13g	Servo digitale 13 G
SPMAR636A	Spektrum™ AR636A 6-Channel Sport Receiver	Spektrum AR636 6-Kanal AS3X-Sportempfänger	Récepteur Spektrum AR636A 6 voies	Ricevente sport 6 canali Spektrum AR636A

Optional Parts • Optionale Bauteile • Pièces optionnelles • Pezzi opzionali

Part # Nummer Numéro Codice	Description	Beschreibung	Description	Descrizione
EFLA250	Park Flyer Tool Assortment, 5 pc	Park Flyer Werkzeugsortiment, 5 teilig	Assortiment d'outils park flyer, 5pc	Park Flyer assortimento attrezzi, 5 pc
EFLAEC302	EC3 Battery Connector, Female (2)	EC3 Akkukabel, Buchse (2)	Prise EC3 femelle (2pc)	EC3 Connettore femmina x batteria (2)
EFLAEC303	EC3 Device/Battery Connector, Male/Female	EC3 Kabelsatz, Stecker/Buchse	Prise EC3 male/femelle	EC3 Connettore batteria maschio/femmina
EFLB22003S30	11.1V 3S 30C 2200MAH Li-Po	11.1V 3S 30C 2200mAh LiPo	Li-Po 3S 11,1V 2200mA 30C	11.1V 3S 30C 2200MAH Li-Po
EFLB30003S30	11.1V 3S 30C 3000MAH Li-Po	11.1V 3S 30C 3000mAh LiPo	Li-Po 3S 11,1V 3000mA 30C	11.1V 3S 30C 3000MAH Li-Po
EFLB32003S30	11.1V 3S 30C 3200MAH Li-Po	11.1V 3S 30C 3200mAh LiPo	Li-Po 3S 11,1V 3200mA 30C	11.1V 3S 30C 3200MAH Li-Po
DYNC3005	Passport Duo 400W Dual AC/DC Touch Charger	Passport Duo 400 W Duales Wechsel-/Gleichstrom-Ladegerät	Chargeur Passport Duo 400W AC/DC, écran tactile	Caricabatteria AC/DC Passport Duo Touch 400 W
KXSC1004	KX50D Duo 2 x 50W AC/DC Charger	KX50D Duo 2 x 50 W Wechsel-/Gleichstrom-Ladegerät	Chargeur KX50D Duo 2 x 50W AS/DC	Caricabatteria AC/DC KX50D Duo 2 x 50 W
DYNC2010CA	Prophet Sport Plus 50W AC DC Charger	Dynamite Ladegerät Prophet Sport Plus 50W AC/DC EU	Chargeur Prophet Sport Plus 50W AC DC	Caricabatteria Prophet Sport Plus 50W AC DC
SPMA3081	AS3X Programming Cable - Audio Interface	Spektrum Audio-Interface AS3X Empfänger Programmierkabel	Câble de programmation audio AS3X pour smartphone	Cavo di programmazione AS3X - Interfaccia audio
SPMA3065	AS3X Programming Cable - USB Interface	Spektrum USB-Interface AS3X Empfänger Programmierkabel	Câble de programmation USB AS3X pour PC	Cavo di programmazione AS3X - Interfaccia USB
EFLA111	Li-Po Cell Voltage Checker	Li-Po Cell Voltage Checker	Testeur de tension d'éléments Li-Po	Voltmetro verifica batterie LiPo
DYN1405	Li-Po Charge Protection Bag, Large	Dynamite LiPoCharge Protection Bag groß	Sac de charge Li-Po, grand modèle	Sacchetto grande di protezione per carica LiPo
DYN1400	Li-Po Charge Protection Bag, Small	Dynamite LiPoCharge Protection Bag klein	Sac de charge Li-Po, petit modèle	Sacchetto piccolo di protezione per carica LiPo
	DXe DSMX 6-Channel Transmitter	Spektrum DXe DSMX 6-Kanal Sender	Emetteur DXe DSMX 6 voies	DXe DSMX Trasmettitore 6 canali
	DX6eDSMX 6-Channel Transmitter	Spektrum DX6e DSMX 6-Kanal Sender	Emetteur DX6e DSMX 6 voies	DX6e DSMX Trasmettitore 6 canali
	DX6 DSMX 6-Channel Transmitter	Spektrum DX6 DSMX 6-Kanal Sender	Emetteur DX6 DSMX 6 voies	DX6 DSMX Trasmettitore 6 canali
	DX7G2 DSMX 7-Channel Transmitter	Spektrum DX7 DSMX 7 Kanal Sender	Emetteur DX7 DSMX 7 voies	DX7 DSMX Trasmettitore 7 canali
	DX8G2 DSMX 8-Channel Transmitter	Spektrum DX8G2 DSMX 8 Kanal Sender	Emetteur DX8G2 DSMX 8 voies	DX8G2 DSMX Trasmettitore 8 canali
	DX9 DSMX 9-Channel Transmitter	Spektrum DX9 DSMX 9 Kanal Sender	Emetteur DX9 DSMX 9 voies	DX9 DSMX Trasmettitore 9 canali
	DX18 DSMX 18-Channel Transmitter	Spektrum DX18 DSMX 18 Kanal Sender	Emetteur DX18 DSMX 18 voies	DX18 DSMX Trasmettitore 18 canali
	DX20 DSMX 20-Channel Transmitter	Spektrum DX 20 DSMX 20 Kanal Sender	Emetteur DX20 DSMX 20 voies	DX 20 DSMX Trasmettitore 20 canali



Opterra™

© 2016 Horizon Hobby, LLC.

E-flite, Opterra, AS3X, DSM, DSM2, DSMX, the DSMX logo, Bind-N-Fly, BNF, the BNF logo, Plug-N-Play, ModelMatch, Dynamite, Prophet, EC3, SAFE, the SAFE logo, and the Horizon Hobby logo are trademarks or registered trademarks of Horizon Hobby, LLC.

The Spektrum trademark is used with permission of Bachmann Industries, Inc.

Futaba is a registered trademark of Futaba Denshi Kogyo Kabushiki Kaisha Corporation of Japan.

All other trademarks, service marks and logos are property of their respective owners.

US 9,056,667. US 8,672,726. Other patents pending.

<http://www.e-fliterc.com/>